

octopus 14

DESCRIPTION OF TECHNICAL SPECIFICATIONS

The Octopus 14 model is available in two versions:

-Max. load 200 kg without movement limitations.

-Max. load 200 kg but the jib cannot be extended / max. load 120 kg with jib movement permitted.

The Octopus 14 is able to operate with a compact outrigger system.

Fitted (on request) with a track drive system which can be widened hydraulically to provide greater stability during all movement (truck loading/unloading up/down a ramp, off-road movements).

A battery powered version is available.

BASE FRAME

Sheet steel structure. Hydraulically operated track drive system with rubber track pads providing a wide support surface. The tracks, powered separately and fitted with safety brakes, allow for easy operation on steep gradients. The base frame houses all the electrical and hydraulic components as well as the heat engine and electric motor which create the hydraulic power required for machine operation.

OUTRIGGERS

Stability is provided by 4 outriggers actuated using hydraulic cylinders. The lower part of each outrigger is fitted with a hinged, ground-support plate which can be articulated in all directions for perfect conformity with the terrain. The outriggers are stowed fully within the man body of the machinery.

BOOM SUPPORT

Made from extremely resistant sheet steel. Rotation is controlled by a hydraulic gear motor using a helical gear/worm screw mechanism.

TWIN PANTOGRAPH

Fitted with a twin pantograph articulation system ensuring unrivalled performance and movement for elevated work platforms of this type.

BOOM AND JIB

Designed with 2 components, including a telescopic one, made from steel with a very high enervation limit.

The boom is extended using an internal cylinder.

Jib actuated by a hydraulic cylinder and consisting of 2 bars for pantograph movement. Jib rotation is 85°.

BUCKET

Made entirely from aluminium. Fitted with front opening with safety barrier and gravity latch for easy operator access. The bucket is secured using a quick-release system ensuring extremely compact dimensions when the equipment is being moved.



OIL&STEEL SPA

Via Verdi 22
41018 San Cesario Sul Panaro
Modena - Italy

Subject to management and coordination
by PM Group spa sole shareholder of company
Modena register of companies no. 280699
Tel. +39 059 936811 Fax +39 059 936413

SHARE CAPITAL € 362,400.00 (fully paid-up)
TAX CODE/VAT NO. 02313650364
www.oilsteel.com – info@oilsteel.com

BUCKET LEVELLING

Hydraulic parallelogram system allowing for corrections in the event of bucket positioning misalignment.

CONTROLS

Electro-hydraulic for transfer and stabilisation. Remote control supplied as standard.

Proportional hydraulic for bucket control with two operating positions, one in the bucket and one on the main boom support.

DEVICES FITTED AS STANDARD

- Boom outrigger interlock
- Attachments for safety harnesses on the bucket
- User and maintenance booklet
- Bucket load limiter
- Manual pump for emergency descent
- Electrical system overload switches
- Hydraulic circuit max. pressure valve
- Cylinder lock valves
- Adjustable track drive from 780 mm to 1100 mm
- Removable two-operator bucket 1400 x 700 x h 1100
- Machine operation hour counter
- Single-phase, auxiliary 220 V - 110 V AC - 2.2 kW electric pump including electrical control panel and battery charger powered using an external source
- Machinery guard
- Honda 13 hp petrol engine
- Outriggers fitted with illuminated position indicators
- Engine and auxiliary motor can be switched ON/OFF from the bucket
- Pair of black track belts
- Electrically controlled emergency descent
- Automatic brake during transfer
- Automatic brake during rotation
- Water and air supply line to bucket
- Single-phase, 220 or 110 V AC power socket and differential overload switch fitted on bucket
- Control priority on bucket
- Engine emergency stop button
- Remote control unit for transfer, outrigger stabilisation and track opening controls
- Transfer warning siren
- Good stability warning lights
- Engine starter control unit on bucket



OctoPlus 14

OIL&STEEL SPA

Via Verdi 22
41018 San Cesario Sul Panaro
Modena - Italy

Subject to management and coordination
by PM Group spa sole shareholder of company
Modena register of companies no. 280699
Tel. +39 059 936811 Fax +39 059 936413

SHARE CAPITAL € 362,400.00 (fully paid-up)
TAX CODE/VAT NO. 02313650364
www.oilsteel.com – info@oilsteel.com

SPECIFICATIONS AND PERFORMANCE

Max. operating height	14 m
Max. boom overhang	6.5 m
Maximum load	200 kg / 2 operators
Max. no. of operators	2
Removable aluminium bucket dimensions	1400 x 700 x h 1100 mm
Controls	aerial components: proportional hydraulic - outriggers and transfer: electro-hydraulic
Boom support rotation	300°
Vehicle kerb weight	1900 kg

OPTIONS AVAILABLE ON REQUEST

- Pair of white non-marking tracks for use indoors instead of the standard ones
- Wax protection system for shipping by sea
- Bucket fitted with 60 W light powered by the batteries supplied including 12 V DC socket
- Gradient detection device with max. gradient warning siren
- 12 V electric socket on the bucket
- Remote control unit with automatic stabilisation
- Decals on boom
- Automatic stabilisation with wired control unit
- Auxiliary Lombardini 15 hp diesel engine
- Elevated work platform and boom treated with corrosion-resistant paint
- Painting options (standard white RAL 9016)
- 2 safety harness kits with rope
- Set of 4 large Nylatron outrigger support plates with diameter of 300 mm instead of the standard ones

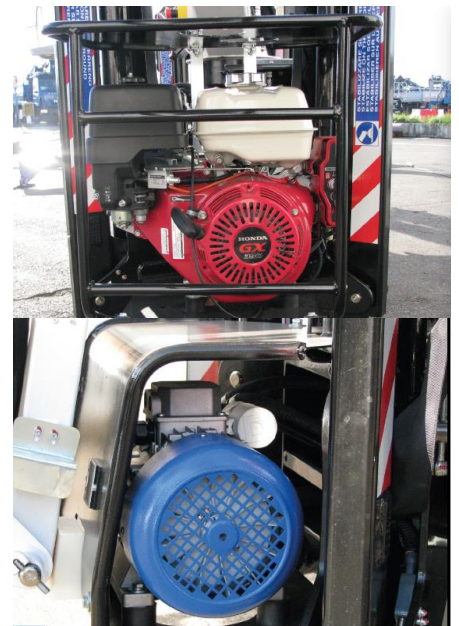

OPERATING AREA AND MACHINE DRAWINGS



ILTEEL SPA

li 22
an Cesario Sul Panaro
1 - Italy

Subject to management and coordination
by PM Group spa sole shareholder of company
Modena register of companies no. 280699
Tel. +39 059 936811 Fax +39 059 936413

SHARE CAPITAL € 3
TAX CODE/VAT NO
www.oilsteel.com -

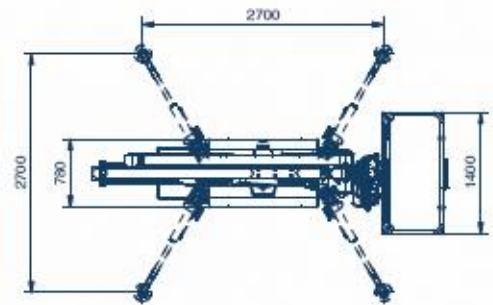
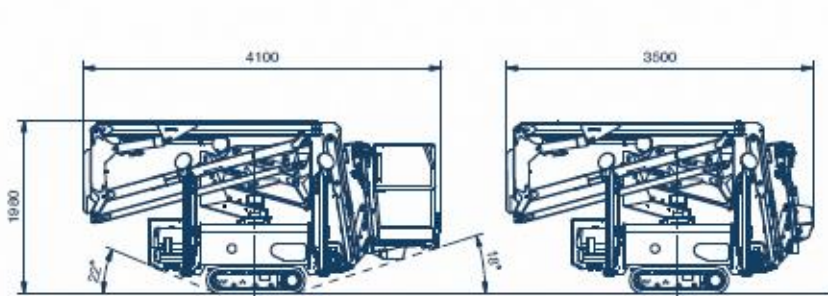
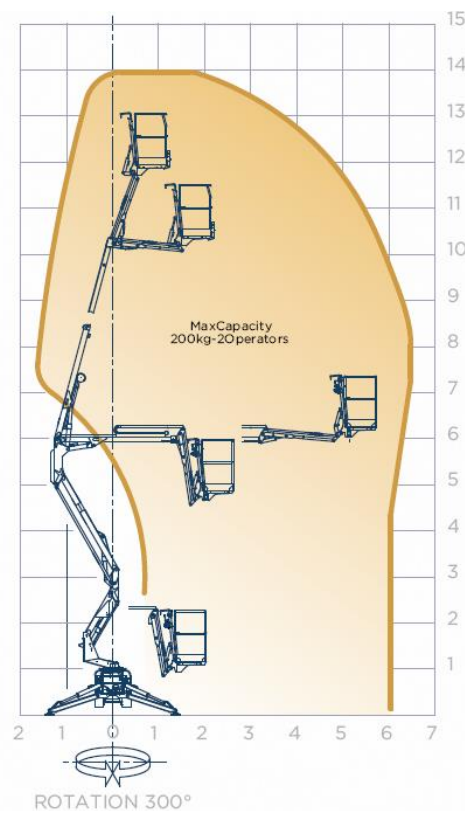
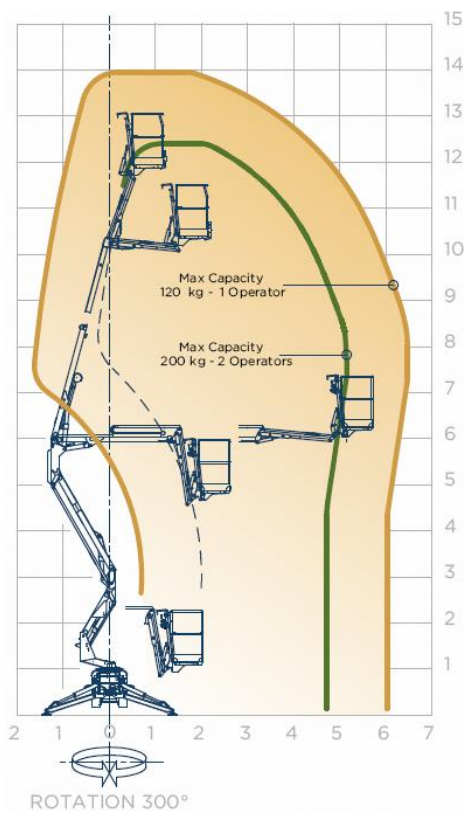

OIL&STEEL SPA

Via Verdi 22
41018 San Cesario Sul Panaro
Modena - Italy

Subject to management and coordination
by PM Group spa sole shareholder of company
Modena register of companies no. 280699
Tel. +39 059 936811 Fax +39 059 936413

SHARE CAPITAL € 362,400.00 (fully paid-up)
TAX CODE/VAT NO. 02313650364
www.oilsteel.com – info@oilsteel.com