

ARTICULATING BOOM LIFTS

	450A 450 Series II	450AJ 450 Series II
Platform Height	13.72 m	13.72 m
Horizontal Outreach	7.47 m	7.47 m
Up and Over Height	7.67 m	7.67 m
Swing (non continuous)	360°	360°
Platform Capacity – Unrestricted	230 kg	230 kg
Platform Rotator (Hydraulic)	180°	170°
Jib – Overall Length	—	1.24 m
Jib - Range of articulation	—	145° (+78°/ -67°)
A. Platform Size	0.76 m x 1.83 m	0.76 m x 1.83 m
B. Overall Width	1.98 m	1.98 m
C. Tailswing (working condition)	Zero	Zero
D. Stowed Height	2.30 m	2.30 m
E. Stowed Length	6.50 m	6.53 m
F. Wheelbase	1.98 m	1.98 m
G. Ground Clearance	0.36 m	0.36 m
Gross Vehicle Weight ¹	7,000 kg	7,100 kg
Maximum Ground Bearing Pressure	5.3 kg/cm ²	5.48 kg/cm ²
Drive Speed 2WD	5.6 km/h	5.6 km/h
Drive Speed 4WD	7.2 km/h	7.2 km/h
Gradeability 2WD	30%	30%
Gradeability 4WD	45%	45%
Tyres (Foam Filled)	12 x 16.5	12 x 16.5
Axle Oscillation ²	0.20 m	0.20 m
Turning Radius – Inside	1.73 m	1.73 m
Turning Radius – Outside	4.27 m	4.27 m
Diesel Engine (Deutz F3M1011F)	35 kW	35 kW
Fuel Tank Capacity	62.5 L	62.5 L
Hydraulic Reservoir	113.6 L	113.6 L
Auxiliary Power	12V DC	12V DC

¹ Certain options or country standards will increase weight.

² Optional on models 450A and 450AJ.

Specifications may change to meet country standards or with the addition of optional equipment.



JLG MODEL 450A (450 Series II)

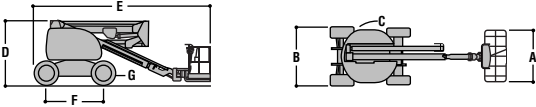
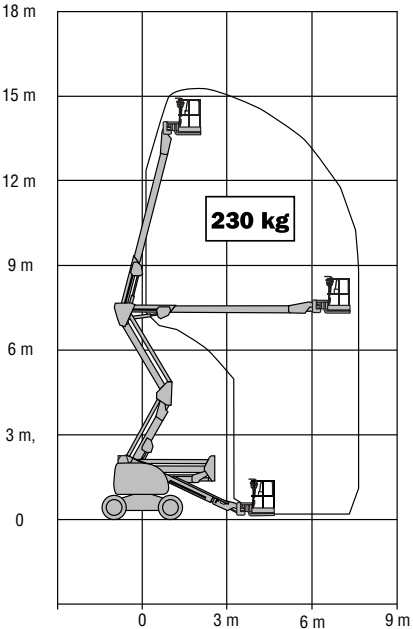

JLG MODEL 450AJ (450 Series II)

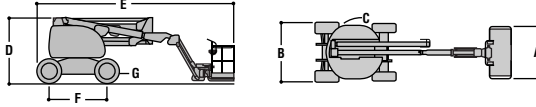
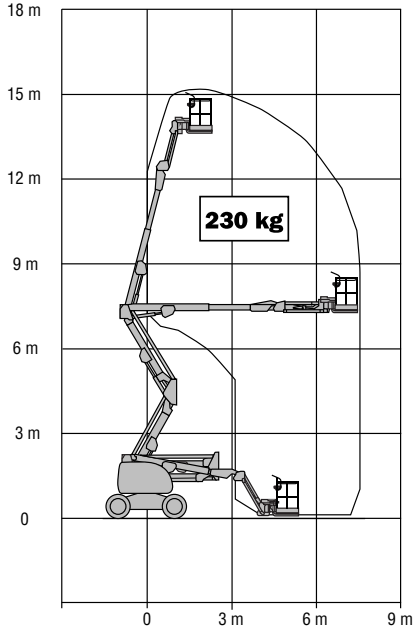

ARTICULATING BOOM LIFTS

510AJ

Platform Height	15.81 m
Horizontal Outreach	9.48 m
Up and Over Height	7.63 m
Swing (non continuous)	360°
Platform Capacity – Unrestricted	230 kg
Platform Rotator (Hydraulic)	180°
Jib – Overall Length	1.24 m
Jib - Range of articulation	145° (+75° / -70°)
A. Platform Size	0.76 m x 1.83 m
B. Overall Width	2.26 m
C. Tailswing (working condition)	Zero
D. Stowed Height	2.30 m
E. Stowed Length	7.68 m
F. Wheelbase	2.34 m
G. Ground Clearance	0.36 m
Gross Vehicle Weight ¹	7,300 kg
Maximum Ground Bearing Pressure	3.37 kg/cm ²
Drive Speed 2WD	—
Drive Speed 4WD	7.2 km/h
Gradeability 2WD	—
Gradeability 4WD	45%
Tyres (Foam Filled)	12 x 16.5
Axle Oscillation ²	0.20 m
Turning Radius – Inside	2.00 m
Turning Radius – Outside	5.00 m
Diesel Engine (Deutz F3M1011F)	35 kW
Fuel Tank Capacity	62.5 L
Hydraulic Reservoir	113.6 L
Auxiliary Power	12V DC

¹ Certain options or country standards will increase weight.

² Optional on models 450A and 450AJ.

Specifications may change to meet country standards or with the addition of optional equipment.



JLG MODEL 510AJ

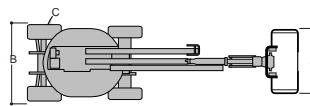
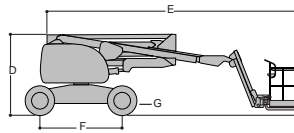
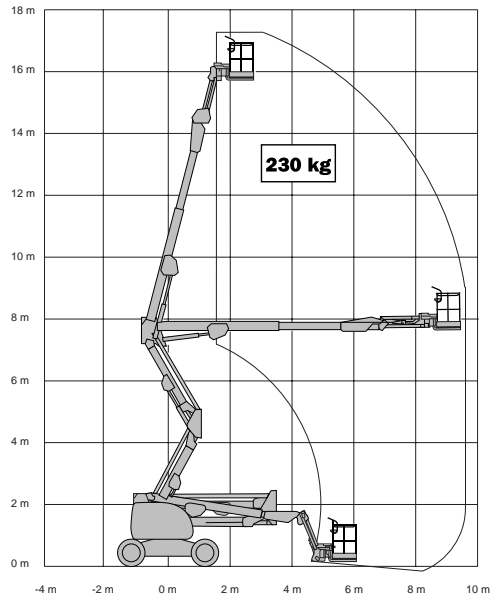

ARTICULATING BOOM LIFTS

	600A	600AJ	600A narrow	600AJ narrow
Platform Height	18.29 m	18.29 m	18.29 m	18.29 m
Horizontal Outreach	12.07 m	12.12 m	12.07 m	12.12 m
Up and Over Height	8.05 m	8.05 m	8.05 m	8.05 m
Swing (Continuous)	360°	360°	360°	360°
Platform Capacity – Unrestricted	230 kg	230 kg	230 kg	230 kg
Platform Rotator (Hydraulic)	180°	180°	180°	180°
Jib – Overall Length	—	1.83 m	—	1.83 m
Jib - Range of articulation	—	135° (+70°/ -65°)	—	135° (+70°/ -65°)
A. Platform Size	0.91 m x 1.83 m	0.91 m x 1.83 m	0.91 m x 1.83 m	0.91 m x 1.83 m
B. Overall Width	2.44 m	2.44 m	2.13 m	2.13 m
C. Tailswing – working condition	Zero	Zero	0.13 m	0.13 m
D. Stowed Height	2.56 m	2.56 m	2.56 m	2.56 m
E. Stowed Length	8.05 m	8.82 m	8.05 m	8.82 m
F. Wheelbase	2.44 m	2.44 m	2.44 m	2.44 m
G. Ground Clearance	0.30 m	0.30 m	0.30 m	0.30 m
Gross Vehicle Weight ¹	10,330 kg	10,650 kg	9,616 kg	10,183 kg
Maximum Ground Bearing Pressure	4.93 kg/cm ²	4.86 kg/cm ²	6.42 kg/cm ²	6.50 kg/cm ²
Drive Speed 2WD	5.6 km/h	5.6 km/h	5.6 km/h	5.6 km/h
Drive Speed 4WD	6.4 km/h	6.4 km/h	—	—
Gradeability 2WD	30%	30%	30%	30%
Gradeability 4WD	45%	45%	—	—
Tyres	14 x 17.5 Foam Filled	14 x 17.5 Foam Filled	14 x 17.5 Solid, Segmented	14 x 17.5 Solid, Segmented
Axle Oscillation (optional)	0.20 m	0.20 m	0.20 m	0.20 m
Turning Radius – Inside 2WS	3.48 m	3.48 m	3.71 m	3.71 m
Turning Radius – Inside 4WS	1.67 m	1.67 m	1.70 m	1.70 m
Turning Radius – Outside 2WS	5.38 m	5.38 m	5.03 m	5.03 m
Turning Radius – Outside 4WS	3.55 m	3.55 m	3.40 m	3.40 m
Diesel Engine – Deutz F4M1011F	48.5 kW	48.5 kW	48.5 kW	48.5 kW
Fuel Tank Capacity	113.6 L	113.6 L	113.6 L	113.6 L
Hydraulic Reservoir	115.8 L	115.8 L	115.8 L	115.8 L
Auxiliary Power	12V DC	12V DC	12V DC	12V DC

¹ Certain options or country standards will increase weight.

Specifications may change to meet country standards or with the addition of optional equipment.



JLG MODEL 600A

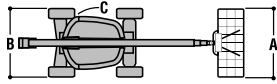
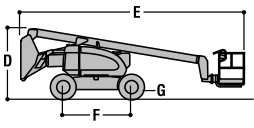
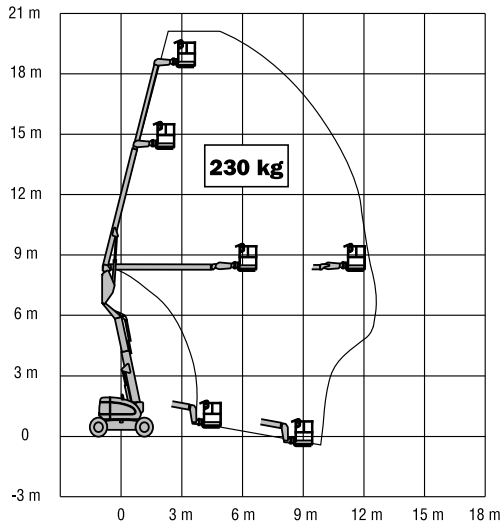

JLG MODEL 600AJ

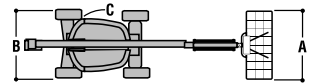
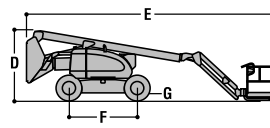
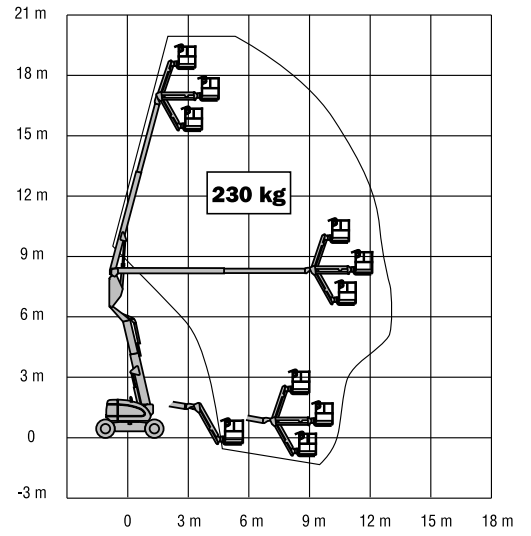

ARTICULATING BOOM LIFTS

	800A	800AJ
Platform Height	24.38 m	24.38 m
Horizontal Outreach	16.15 m	15.74 m
Up and Over Height	9.78 m	9.78 m
Swing (Continuous)	360°	360°
Platform Capacity – Unrestricted	230 kg	230 kg
Platform Rotator (Hydraulic)	180°	180°
Jib – Overall Length	—	1.83 m
Jib - Range of articulation	—	130° (+70°/ -60°)
A. Platform Size	0.91 m x 1.83 m	0.91 m x 1.83 m
B. Overall Width	2.44 m	2.44 m
C. Tailswing – working condition	0.76 m	0.76 m
D. Stowed Height	3.00 m	3.00 m
E. Stowed Length	11.25 m	11.12 m
F. Wheelbase	3.05 m	3.05 m
G. Ground Clearance	0.30 m	0.30 m
Gross Vehicle Weight ¹	15,030 kg	15,030 kg
Maximum Ground Bearing Pressure	5.36 kg/cm ²	5.36 kg/cm ²
Drive Speed 2WD	4.8 km/h	4.8 km/h
Drive Speed 4WD	4.8 km/h	4.8 km/h
Gradeability 2WD	30%	30%
Gradeability 4WD	45%	45%
Tyres	15 x 19.5 Foam Filled	15 x 19.5 Foam Filled
Axle Oscillation (optional)	0.20 m	0.20 m
Turning Radius – Inside 2WS	3.66 m	3.66 m
Turning Radius – Inside 4WS	2.13 m	2.13 m
Turning Radius – Outside 2WS	6.86 m	6.86 m
Turning Radius – Outside 4WS	4.42 m	4.42 m
Diesel Engine – Deutz F4M1011F	48.5 kW	48.5 kW
Fuel Tank Capacity	147.6 L	147.6 L
Hydraulic Reservoir	151.4 L	151.4 L
Auxiliary Power	12V DC	12V DC

¹ Certain options or country standards will increase weight.

Specifications may change to meet country standards or with the addition of optional equipment.



JLG MODEL 800A

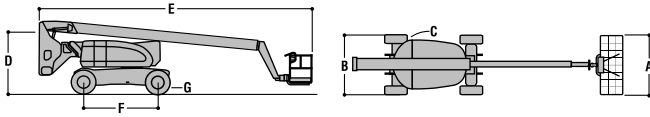
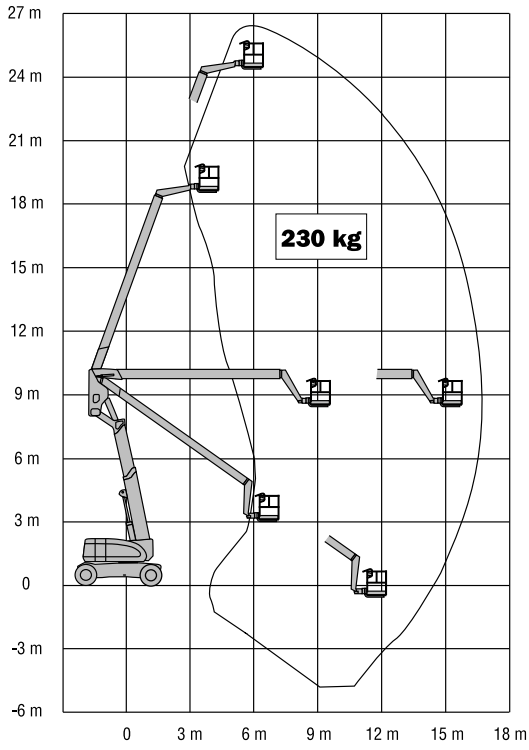

JLG MODEL 800AJ

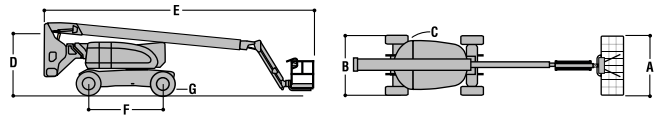
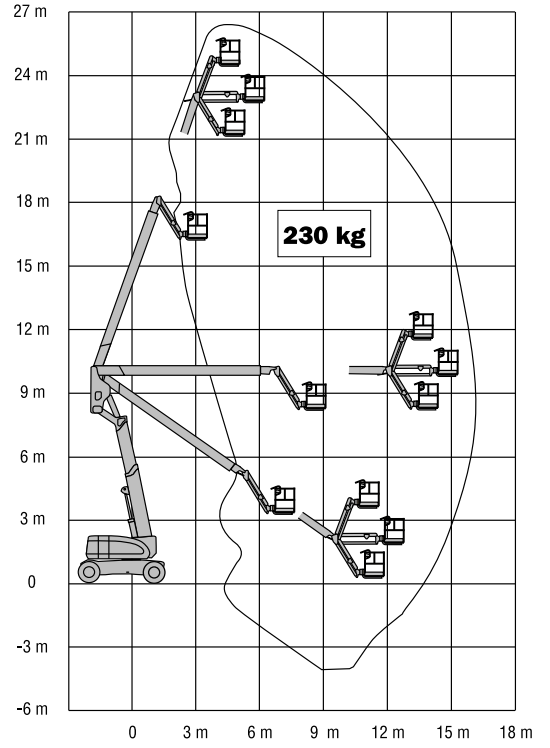

ARTICULATING BOOM LIFTS

1250AJP

Platform Height	38.10 m
Horizontal Outreach	19.25 m
Up and Over Height	18.44 m
Swing (Continuous)	360°
Platform Capacity – Restricted	450 kg
Platform Capacity – Unrestricted	230 kg
Platform Rotator (Hydraulic)	180°
Jib – Overall Length	2.44 m
Jib - Range of articulation	130° Vertical (+75°/-55°)
JibPLUS® - Range of Articulation	125° Horizontal
A. Platform Size	0.91 m x 2.44 m
B. Overall Width (Axles Retracted)	2.49 m
Overall Width (Axles Extended)	3.81 m
C. Tailswing (working condition)	2.26 m
D. Stowed Height	3.05 m
E. Stowed Length	11.46 m
F. Wheelbase	3.81 m
G. Ground Clearance	0.30 m
Gross Vehicle Weight*	19,958 kg
Maximum Ground Bearing Pressure	7.03 kg/cm ²
Drive Speed	5.2 km/h
Gradeability	45%
Tyres	445/50D710 Foam Filled
Axle Oscillation	0.30 m
Turning Radius – Inside (Axles Retracted)	4.39 m
Turning Radius – Inside (Axles Extended)	2.44 m
Turning Radius – Outside (Axles Retracted)	6.86 m
Turning Radius – Outside (Axles Extended)	5.89 m
Diesel Engine - Deutz BF 4M 2011	65 kW
Fuel Tank Capacity	117 L
Hydraulic Reservoir	202 L
Auxiliary Power	12V DC

**Certain options or country standards will increase weight.
Specifications may change to meet country standards or with the addition of optional equipment.*



JLG MODEL 1250AJP

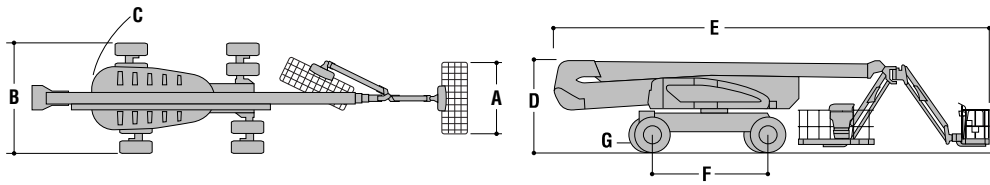
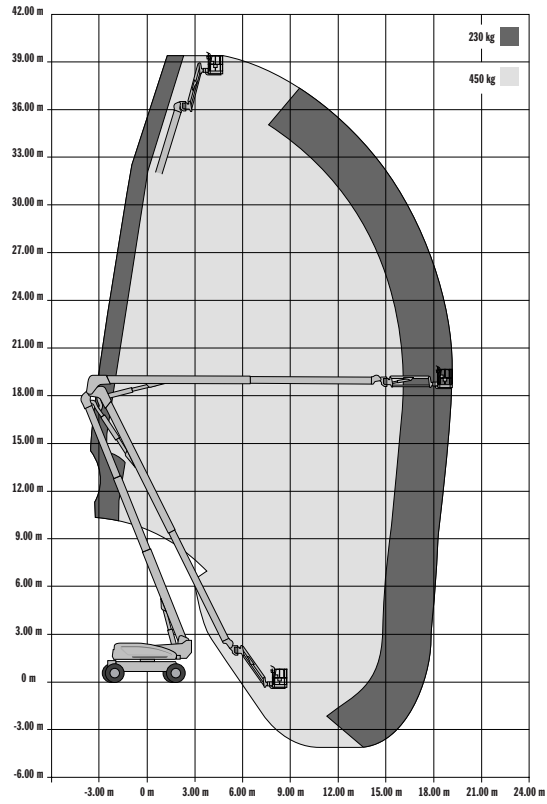

ARTICULATING BOOM LIFTS

150HAX

Platform Height	45.72 m
Horizontal Outreach	24.16 m
Up and Over Height	24.38 m
Swing (Continuous)	360°
Platform Capacity – Unrestricted	230 kg
Platform Rotator (Hydraulic)	165°
A. Platform Size	0.91 m x 2.44 m
B. Overall Width (Axles Retracted)	3.51 m
C. Overall Width (Axles Extended)	5.49 m
D. Tailswing (working condition)	Zero
E. Stowed Height	4.27 m
F. Stowed Length	12.01 m
G. Wheelbase	5.49 m
H. Ground Clearance	0.30 m
Gross Vehicle Weight ¹	25,855 kg
Maximum Ground Bearing Pressure	7.9 kg/cm ²
Maximum Tyre Load	12,000 kg
Drive Speed	4.3 km/h
Gradeability	31%
Tyres	445/65R22.5 Foam Filled
Turning Radius (Inside) - Axles Retracted	4.52 m
Turning Radius (Inside) - Axles Extended	4.45 m
Turning Radius (Outside) - Axles Retracted	8.23 m
Turning Radius (Outside) - Axles Extended	9.17 m
Diesel Engine – Cummins 4B3-9C	58 kW
Fuel Tank Capacity	257.4 L
Hydraulic Reservoir	469.3 L
Auxiliary Power	12V DC

¹ Certain options or country standards will increase weight.

Specifications may change to meet country standards or with the addition of optional equipment.



JLG MODEL 150HAX

