

# Specifications\*

# LEO21GT

MEASUREMENTS	Metric	US
Working height, max.	21,00 m	68 ft 11 in
Horizontal outreach with 250 kg	12,00 m	39 ft 4 in
Up and Over Clearance, max.	9,50 m	31 ft 2 in
Platform height (A)	1,10 m	3 ft 7 in
Platform length (B)	1,40 m	4 ft 7 in
Platform width (C)	0,77 m	2 ft 4 in
Length, overall (D)	6,40 m	20 ft 12 in
Length without basket (E)	5,00 m	16 ft 5 in
Height, travelling position (F)	1,99 m	6 ft 6 in
Width, min. (G)	0,98 m	3 ft 3 in
Ground clearance, max. (H)	0,44 m	1 ft 5 in
Track (L x W) (I)	1,45 m x 0,20 m	4 ft 9 in x 8 in
Length outrigger footprint standard (J)	4,68 m	15 ft 4 in
Width outrigger footprint standard (K)	4,68 m	15 ft 4 in
Length footprint one side narrow (L)	6,31 m	20 ft 8 in
Width footprint one side narrow (M)	3,66 m	12 ft
Width footprint both sides narrow (N)	2,64 m	8 ft 8 in
Outrigger plate Ø	0,18 m	7 in

PRODUCTIVITY	Metric	US
Basket capacity	250 kg	551 lbs
Movable Jib	-	-
Basket rotation	180°	180°
Turret rotation	360°	360°
To be jacked up on ground slope of	16,7°/30 %	16,7°/30 %
Height and width track adjustment	19/46 cm	7 in/1 ft 6 in
Gradeability, max.	16,7°/30 %	16,7°/30 %
Slope angle	19,0°/34 %	19,0°/34 %
Travel speed	4,0 km/h	2.5 mph

WEIGHT	Metric	US
Total weight	2950 kg	6,504 lbs
Live load in travelling position	4,6 kN/m <sup>2</sup>	96.1 psf
Live load in working position	1,5 kN/m <sup>2</sup>	31.3 psf
Point load per outrigger plate, max.	23,7 kN	5328 lbf

POWER	
Standard power sources (Electric & combustion engine)	<b>1) Electric:</b> EU: 230 V, 12,9 A, 2,2 kW US: 115 V, 19.3 A, 1.6 kW <b>2) Petrol/Gas:</b> Vanguard OHV 16 HP (11,93 kW/16 hp)
Optional power source	<b>Diesel:</b> Kubota Z 602 (10,8 kW/14,5 hp)
Fuel tank petrol/gas engine	11,5 l 2.91 gal
Fuel tank capacity Diesel engine	11,5 l 2.91 gal

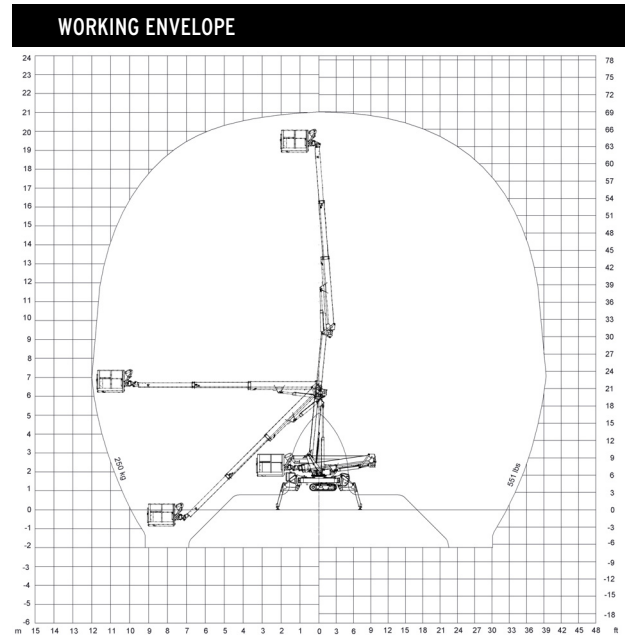
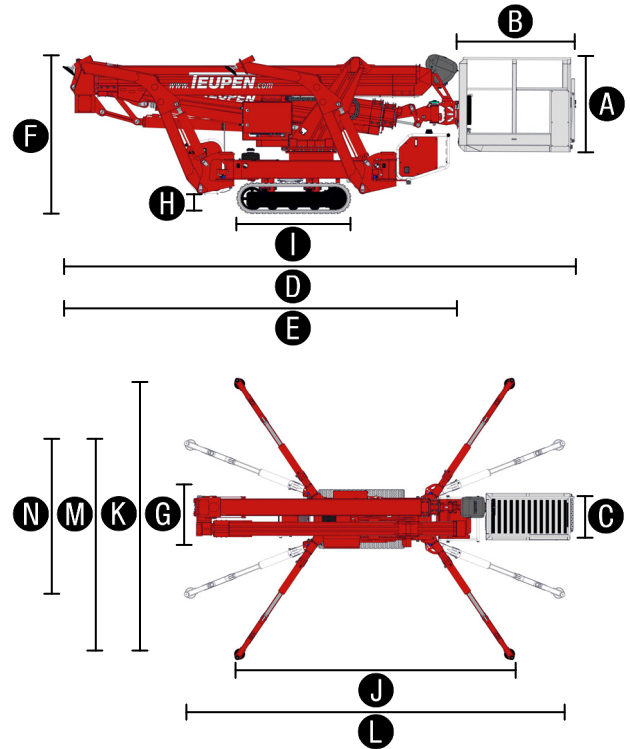

Product specifications are subject to change without notice or obligation. Photographs and drawings in this document are for illustrative purposes only. Refer to the appropriate Operator's Manual for instructions on the proper use of this equipment. Failure to follow the appropriate Operator's Manual when using our equipment or to otherwise act irresponsibly may result in serious injury or death. The only warranty applicable to our equipment is the standard written warranty applicable to the particular product and sale and we make no other warranty, expressed or implied. Products and services listed may be trademarks, service marks or trade-names of Teupen Maschinenbau GmbH and/or its subsidiaries in the U.S.A. and many other countries. "Teupen", "Access redefined" and "LEO Series" are registered Trademarks of Teupen GmbH in the United States of America and many other countries. Version 2013-B © 2013 Teupen Maschinenbau GmbH.

\* preliminary

# Features\*

## TRACK CHASSIS

- Powerful track drive with hydraulic braking system
- Precise maneuvering over sensitive electrohydraulic cable remote control
- Rubber tracks with specially arranged profile providing optimum grip
- White, non-marking rubber tracks
- Mechanically height- und width-adjustable track chassis

## STABILISATION

- Fully-hydraulic, automatic levelling system with outrigger/stabiliser setup monitoring
- Variable outrigger/stabiliser system with one-side or both-sides narrow setup option
- Wear resistant, anti-friction PVC outrigger/stabiliser feet

## BOOM SYSTEM

- Telescoping upper- and lower booms, trapezium-shaped with Teflon sliding blocks
- All functions are available from one control panel
- Electric-proportional controls with intuitive operator guidance
- Robust, lockable control panel with integrated operation and display function
- Self-levelling platform with fully-hydraulic levelling system
- Corner-mounted, 180° turnable basket for extra flexibility
- Boom rotation via high-performance slew ring, worm gear and hydraulic motor
- Resting support system prevents incorrect positioning of boom in transport bracket

## POWER SOURCES

- 230 V electric motor (EU), 115 V electric motor (US)
- Vanguard OHP 16 HP petrol/gas engine (11,93 kW/16 hp)
- Start-Stop switch of combustion engine in the basket

## PRODUCTIVITY, SAFETY, QUALITY

- 230 V (EU), 115 V (US) double power outlet in the basket
- Ergonomically shaped basket with eyelets for safety belts and tool tray
- Lockable storage box for cable remote control
- High-quality paint in RAL 3020 (red)
- Hydraulic emergency lowering via hand pump
- Cables and hoses are safely routed through the boom structure
- Biodegradable hydraulic oil
- Lock valves - hydraulic return valves directly on all hydraulic cylinders
- Relief valves protecting the hydraulic system from too high pressures
- Protective covers for oil-tank, emergency controls and connecting cables and hoses
- Protective covers for electric housing, ground control panel and telescopic cylinder
- Easily removable covers for optimal accessibility
- Hour meter
- Complete second control box on the chassis and error analysis with display
- Fuzzy IV control technology



## OPTIONS

- Kubota Diesel engine Z602 (10,8 kW/14,5 hp) instead of petrol/ gas engine
- Snap hooks on boom
- 4 covers on piston rod (outrigger/stabiliser) cylinders (10 kg/22 lbs additional weight)
- Custom paintwork, one colour, according to RAL scheme (except metallic coatings, signal- or special colors)
- Custom paintwork, two colours, according to RAL scheme (except metallic coatings, signal- or special colors)
- Treecare package, consisting of:
  - Protective cover over control box
  - Covers on piston rod (outrigger/stabiliser) cylinders
- Hydraulically height- und width-adjustable track chassis instead of the mechanically height- and width-adjustable track chassis
- 400 V electric drive instead of 230 V (115 V (US)) electric drive
- Electric emergency lowering (12 kg/24 lbs additional weight)
- 2 headlights on engine unit
- Coming Home Function - automatic return of boom into transport position

## ACCESSORIES

- 4 outrigger/stabiliser pads (450 x 400 x 40 mm/1 ft 5 in x 1 ft 4 in x 1/2 in)
- Lockable storage frame for outrigger/stabiliser pads (4 kg/9 lbs additional weight)
- 4 outrigger/sliding pads (650 x 220 x 60 mm/2 ft 2 in x 9 in x 2/3 in)
- Track mats (2000 x 1000 x 15 mm/6 ft 6 in x 3 ft 3 in x 1/2 in), extra durable rubber
- Safety harness
- 2 protective track covers, made of high-quality polypropylene fabric
- Tandem Low Platform trailer (aluminium) including 4 tension belts (length 3,50 m/11 ft 6 in)
  - Permissible total weight: 3500 kg/7,716 lbs
  - Tandem rubber-sprung axle: 3500 kg/7,716 lbs
  - Net weight: approx. 430 kg/948 lbs
  - Wheels 155/70/R12 ET20
  - Lighting fitting according to EU directives

### Enquiries from Europe, Asia, Middle East & Africa:

Corporate Headquarters  
**Teupen Maschinenbau GmbH**  
 Marie-Curie-Str. 13  
 48599 Gronau, Germany  
 phone +49 2562 8161-0  
 fax +49 2562 8161-888  
 mail@teupen.com  
 www.teupen.com

\* preliminary

### Enquiries from North & South America:

US Office  
**Teupen USA, Inc.**  
 10701 Southern Loop Blvd.  
 Pineville, NC 28134, USA  
 phone (704) 248-9871  
 fax (704) 248-9889  
 infousa@teupen.com  
 www.teupen.com/us